

# Brushless internal rotor motors with low-backlash planetary gears

Drive solutions | Industrial drive engineering 2018-06

**ebmpapst**

The engineer's choice





# Contents.

## **ECl motors**

Information about ECl motors	4
Definitions for ECl motors	6
ECl-42.XX-K1	8
PE040 (planetary gearhead)	10
ECl-63.XX-K1	12
PE060 (planetary gearhead)	14
ECl-80.XX-K1	16
PE080 (planetary gearhead)	18

## **Standards and guidelines**

<b>Operating factor, lifetime, efficiency</b>	<b>22</b>
<b>ebm-papst around the world</b>	<b>23</b>

# Information for ECI motors.

## Key figures

- 3-phase, electronically commutated internal rotor motor with high-performance magnet
  - Power range between 30 and 750 watts
  - High power density realized in a compact design
  - High overload capacity
  - Long service life
  - Very quiet operation
  - Detection of rotor position via Hall sensors
  - Customer-specific winding layouts
  - Winding insulation as per insulation class E
  - Protection class IP 54 as per EN 60 034-5: up to IP 65
- 
- Various motor types which can be combined with planetary and crown gearheads
  - Optional integrated control electronics
  - Optional encoder and brake modules

## Approvals

- Support with the accreditation of products in different economic areas and markets
- As an experienced and competent partner we would be happy to support you
- Possible approvals include CE, CCC, UL, CSA, EAC
- Additional approvals on request

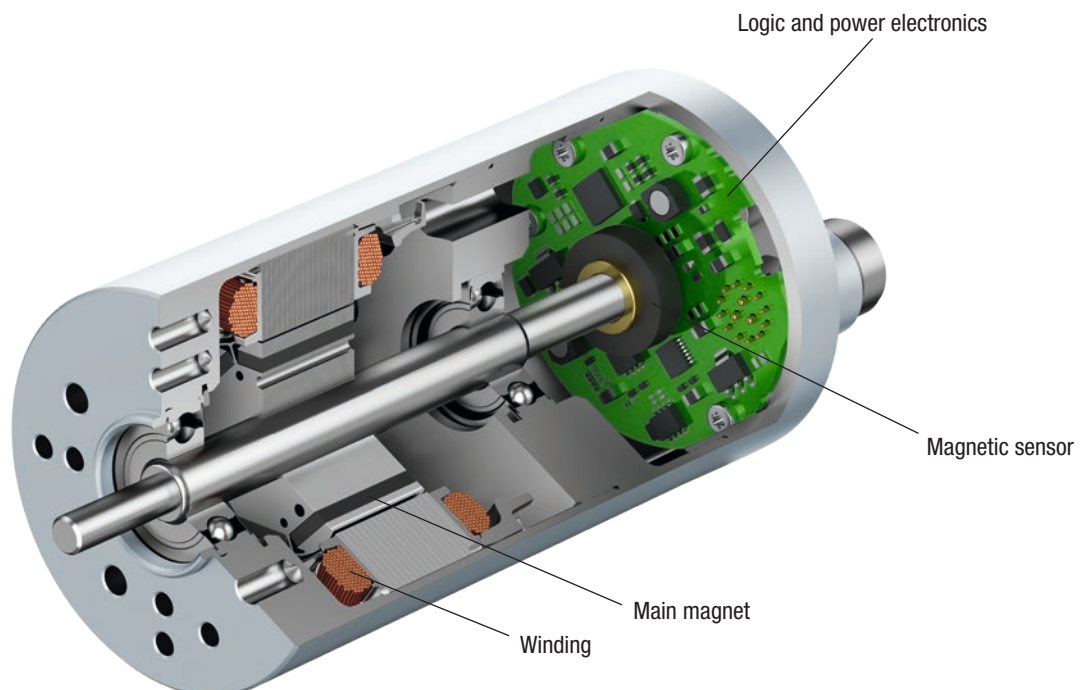

The data in this catalog contain product specifications, but are not a guarantee of particular properties.

All information is based on the measuring conditions mentioned below. Operation of motors using reference electronics at an ambient temperature of max. 40°C when attached (thermally conductive) to a free-standing steel plate of the following size:  
Steel plate 105 x 105 x 10 mm

The **nominal operating point** is the basis for the electromagnetic design of the motor from the point of view of the maximum possible continuous output of the motor and is specified by the nominal values described here.

The values mentioned are typical values for the design in question and are also subject to the tolerances included in the specifications or drawings. Unless otherwise stated, the supplements and safety notes contained in the relevant operating and assembly instructions must be kept at all times. Subject to availability and technical alterations.

### Nominal output power $P_N$ [W]

The output power which the motor can produce continuously; it is calculated from nominal torque and nominal speed. For the electromagnetic design of the motor the determination of the nominal operating point is based on the fact that the nominal output power is close the maximum output power of the motor.

### Nominal voltage $U_{BN}, U_N, U_B$ [V DC]

The DC voltage (i.e. DC voltage range) that is applied to the commutation electronics as a system supply voltage. All nominal values listed in the technical tables of the individual motors refer to this voltage. Motor applications are, however, not restricted to this voltage.

### Nominal speed $n_N$ [rpm]

The speed at which the motor may be operated continuously while delivering nominal torque at an ambient temperature of 40°C and nominal output torque. It is an operating point on the max. motor curve based on an ideal electronics with negligible losses.

### Nominal torque $M_N$ [mNm]

The torque that the motor can deliver continuously at an ambient temperature of 40°C and nominal speed.

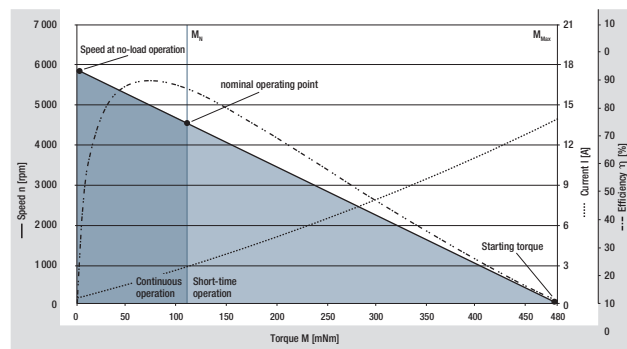

The illustrated curves are idealized representations based on the figures in the tables.

### Nominal current $I_{BN}$

The current that is drawn from the system supply when the motor delivers nominal torque at nominal speed.

### Speed at no-load operation $n_L$ [rpm]

The speed that takes effect at the nominal voltage and with unloaded motor. The theoretical possible speed at no-load operation can, in some cases, be limited by the mechanical ceiling speed.

### No-load current $I_{BL}$ [A]

Is established with nominal voltage and unloaded motor; is largely influenced by the bearing friction. For drive systems that have a separate supply for power and logic, the no-load current is called  $I_L$ . This no-load current is the sum of the power supply ( $I_{zK}$ ) and the low-power logic supply ( $I_b$ ).

### Permanent stall torque $M_{Bn0}$ [mNm]

Is the maximum permissible torque with which the motor may be permanently loaded when the rotor is locked.

### Permissible eff. continuous stall current $I_{noeff}$ [A]

Is the maximum permissible current which at a stalled motor is allowed to flow into the motor lead as an effective value.

# Definitions for ECI motors.

## **Continuous stall power $P_{Bn0}$ [W]**

Is an approximate value for the voltage-independent maximum permitted output ( $P=U \times I$ ) that can be taken from the DC voltage source in holding status.

## **Permissible peak torque short-term $M_{max}$ [mNm]**

Is the torque which the motor can usually deliver in a short time.

## **Permissible peak current, motor lead $I_{max}$ [A]**

Is the current that must flow in to the motor lead as a peak value to achieve the short-time peak torque.

## **Induced voltage $U_{imax}$ [V/1 000 rpm]**

Maximum value of the induced voltage between two motor leads at 1 000 rpm. It is a dimension for the electromagnetic utilization of the motor.

## **Connection resistance $R_v$ [Ohm]**

The winding resistance that is measured at 20°C between any two of three winding terminations.

## **Connection inductance $L_v$ [mH]**

The average inductance that is measured at 20°C between any two of three winding terminations using a sinusoidal wave measuring frequency of 1 kHz.

## **Rotor moment of inertia $J_r$ [kgm<sup>2</sup>x10<sup>-6</sup>]**

The mass moment of inertia of the rotor and necessary dimension for the dynamic characteristics of the motor.

## **Protection class**

Information on the protection class; it describes protection against foreign particles (Point 1) and water (Point 2).

## **Permissible ambient temperature range $T_v$ [°C]**

Defines the minimum and maximum permissible ambient temperature to which the mentioned performance values apply when the motor is in operation. The permissible winding temperature in the motor (115°C for insulation Class E, as per EN 60 034-1) </1125 should not be exceeded.

## **Weight $m$ [kg]**

Weight of the delivered unit without additional units or packaging.

## **Max. shaft load $F_{radial}/F_{axial}$ [N]**

The permissible forces are divided into radial and axial load values. They are based on the maximum permissible values for the motor bearing during operation at normal rating and a defined service life expectancy  $L_{10}$ .

## **Service life $L_{10}$**

The values for the  $L_{10}$  service life specified in conjunction with the permitted bearing loads have been calculated to DIN ISO 281. In addition to the specified values, this calculation is based on operation of the motor at nominal conditions (nominal torque, nominal speed) and an ambient temperature of max. 40°C. Therefore, the service life information is explicitly not a guarantee of service life, but strictly a theoretical quality figure.

## **Max. reverse voltage [V DC]**

When the braking function is activated and when the set value step change is negative, the motor operates in controlled braking mode. In this operating state, the large part of the braking energy is fed back to the intermediate circuit until the max. reverse voltage is reached and the electronics prevent a further increase beyond this value by chopped braking. This behavior should be given special consideration when selecting the system supply.

## **Set value input**

Speed setting via an analogue interface for DC voltage.

Depending on the drive design, the set speed can be configured in a range from 0 ...  $n_{max}$ , where the minimum possible speed value (with limited control quality) is about 0 rpm (sine commutation)

or approx. 50 to 100 rpm (block commutation). (Relevant only for drives with integrated operating electronics).

## **Recommended speed range [rpm]**

Speed control range within which the speed control accuracy stipulated in the system specification is complied with.

### Starting torque [mNm]

Is the torque that can be delivered over a short time when the motor is started based on the electromagnetic motor characteristics and the set current limitation.

### Effective torque $M_{\text{eff}}$ [mNm]

For cycle operation (e.g. "S5" operating mode – intermittent duty with the effect of the startup losses and the losses due to electrical braking on the heating), the effective torque corresponding to continuous operation ("S1" operating mode) is determined according to the following formula:

$$M_{\text{eff}} = \sqrt{\frac{M_A^2 \cdot t_A + M_L^2 \cdot t_B + M_{Br}^2 \cdot t_{Br}}{t_A + t_B + t_{Br} + t_{St}}}$$

$M_A$	Starting torque	$M_{Br}$	Braking
$t_A$	Acceleration time	$t_{Br}$	Braking time
$M_L$	Load torque	$t_{St}$	Standstill time
$t_B$	Load period		

At an ambient temperature of 40°C this effective torque must not be greater than the nominal torque  $M_N$  listed in the catalog for the selected motor. For intermittent operation (operating mode S3 with  $t_r$  = relative on period) the following permissible load moment applies:

$$M_L = M_N \cdot \sqrt{\frac{100}{t_r}}$$

### System selection

When selecting a motor and operating for a drive system, consideration should be given to the fact that the values permitted for the motor should not be exceeded by the electronics. Likewise, the relationship shown in the commutation sequences between the sequence of Hall signals and the corresponding switching times and switching states of the output stage at the phase supply lines must be observed in order to attain optimum operation of the motor.

Please contact the manufacturer if the products are operated or stored under non standard environmental conditions.

# ECI motor.

## ECI-42.XX-K1



- Highly dynamic 3-phase internal rotor motor with EC technology
- Low cogging torque
- Robust, noise-optimized ball bearing system for a long service life
- High efficiency and high power density realized in a compact design
- Basic motor with electronic module K1 for operation with external control electronics
- Mechanical design and interfaces designed for modular flexibility
- Protection class IP 40 (higher on request) and connection by wires

Nominal data					
Type		ECI-42.20-K1-B00	ECI-42.20-K1-D00	ECI-42.40-K1-B00	ECI-42.40-K1-D00
Nominal voltage ( $U_N$ )	V DC	24	48	24	48
Nominal speed ( $n_N$ )**	rpm	4 000			
Nominal torque ( $M_N$ )**	mNm	110	110	220	220
Nominal current ( $I_N$ )**	A	2.50	1.30	5.10	2.60
Nominal output power ( $P_N$ )**	W	46	46	92	92
Starting torque ( $M_{max}$ )	mNm	480	480	960	960
Permissible peak current ( $I_{max}$ )***	A	14	7	21	11
Speed at no-load operation ( $n_l$ )	rpm	5 900	5 900	5 700	5 700
No-load current ( $I_l$ )	A	0.33	0.10	0.40	0.20
Permanent stall torque ( $M_{NO}$ )	mNm	100	100	200	200
Recommended speed control range	rpm	0 ... 5 000			
Rotor moment of inertia ( $J_R$ )	kgm <sup>2</sup> x10 <sup>-6</sup>	3.42	3.42	6.70	6.70
Motor constant ( $K_E$ )	mVs/rad	40.9	84.2	42.8	83.9
Connection resistance ( $R_c$ )	Ω	0.85	3.20	0.39	1.50
Connection inductance ( $L_c$ )	mH	1.10	4.50	0.50	1.84
Overload protection		To be implemented via the control electronics			
Permissible ambient temperature range ( $T_U$ )	°C	0 ... +40			
Weight	kg	0.33	0.33	0.48	0.48
Order no. (wire interface)*	IP 40	932 4220 122	932 4220 123	932 4240 122	932 4240 123
Subject to alterations		* Classification of protection class refers to installed state with sealing on the flange side			
		** At $T_U$ max. 40°C			
Preferred type: ready to ship in 48 hours		*** Permissible time for peak current: max. 1 sec. – to be repeated only after complete cool down			

Additional information regarding the attachment components can be found in the main catalog or on the IDT website ([idt.ebmpapst.com](http://idt.ebmpapst.com))



## Characteristic curve

ECI-42.20, 24 V (at 25°C)

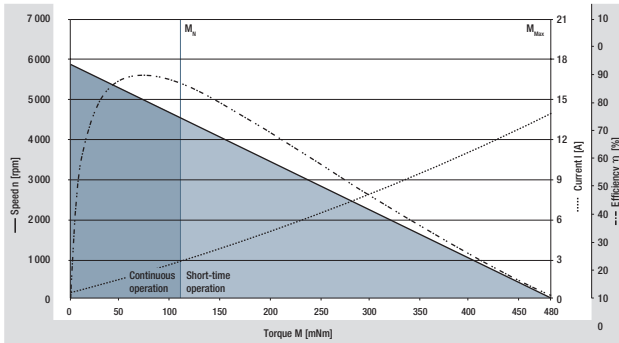

<sup>1)</sup> Nominal data, see table

Characteristic curve 48 V on request

ECI-42.40, 24 V (at 25°C)

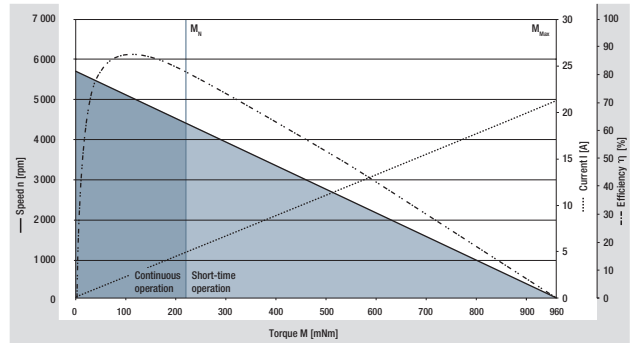

<sup>1)</sup> Nominal data, see table

Characteristic curve 48 V on request

## Modular construction kit

### Brake system

Spring-applied brake  
BFK 457-01

### Encoder system

Optical incremental encoder  
HEDS 5500

### Recommended external control electronics

VTD-XX.XX-K3	Speed
VTD-XX.XX-K4S	Position
VTD-60.13-K5SB	Position

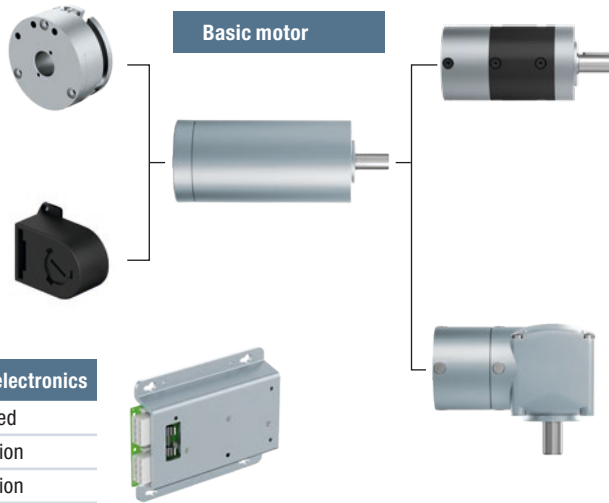

### Planetary gearheads

PE040 (page 11)  
NoiselessPlus 42  
Performax® 42  
Performax®Plus 42

### Crown gearheads

EtaCrown® 52  
EtaCrown®Plus 42

For motor-gearbox combinations, depending on the choice of the single components, the maximum allowable torque (gearbox) can be exceeded or respectively not reached.

# Planetary gearheads.

PE040



Image of 1-stage gearhead

- Case-hardened and ground ring gears
- Case hardened and ground planetary and sun gears ensure increased transmission quality and a long service life
- Low torsional play
- Easiest adaptation of motor and planetary gear through exchangeable flange modular system
- High level of flexibility through proven hollow shaft drive concept
- Integrated axial longitudinal compensation for compensation of the thermally-induced longitudinal expansion of the PTO shaft
- High efficiency and low-noise operation due to high tooth flank quality, needle-mounted planetary gears and high quality lubricant
- High torsional stiffness and high emergency stop torque due to robust gear design and optimized gear geometry

Nominal data					
Gearheads		PE040.1		PE040.2	
Reduction ratio*		5	8	25	40
No. of stages		1		2	
Efficiency		0.96		0.94	
Max. input speed (n <sub>i</sub> )	rpm	6 500		6 500	
Rated output torque (M <sub>ab</sub> )	Nm	16	7	21	21
Max. acceleration torque (M <sub>max</sub> )**	Nm	25.6	11.62	33.6	33.6
Emergency stop torque (M <sub>Not</sub> )***	Nm	32	14	42	42
Gear play	arcmin	≤14		≤18	
Permissible operating temperature (T <sub>v</sub> )	°C	-25 ... +90		-20 ... +80	
Operating mode		S1		S1	
Protection class	IP	64		64	
Weight	kg	0.4		0.5	
Shaft load radial	N	165		165	
Shaft load axial	N	165		165	
Service life	h	30 000		30 000	
Lubrication		Maintenance-free grease lubrication for life			
Installation position		any			
Subject to alterations		* Additional reductions and 3-stage designs on request ** Permitted for 30 000 loading cycles *** 1 000 times during the entire service life			

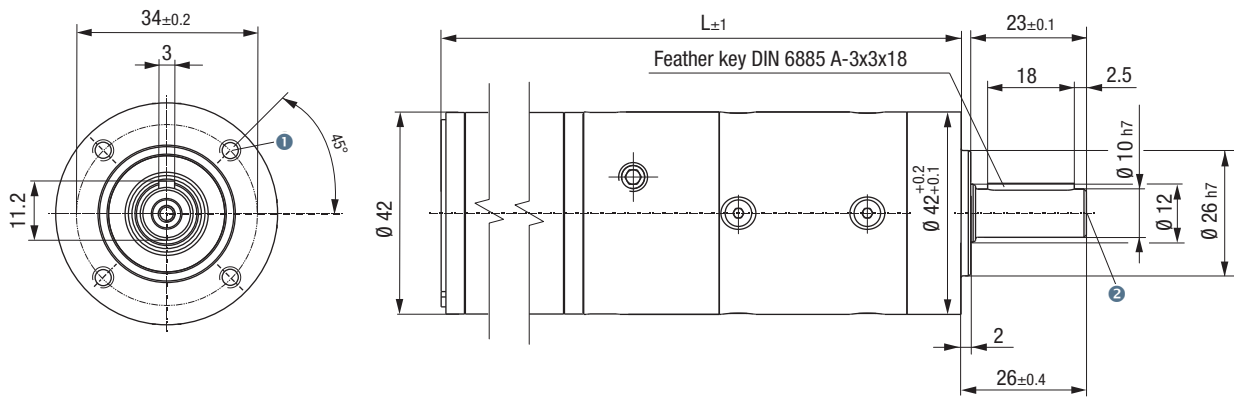

- ❶ 4 x M4 / 6 deep
- ❷ 1 x M3 / 9 deep / DIN 332

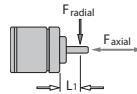

$F_{axial}$  165 N  
 $F_{radial}$  165 N  
 $L1$  13 mm

Permissible shaft load at nominal speed and life expectancy  $L_{10}$  (nominal operation) and operating factor  $C_b = 1$  (see page 22) of 30 000 h (at  $T_U$  40°C).

**Length of the possible motor / gearhead combinations**

Motor / gearhead		L - 1-stage	L - 2-stage	L - 3-stage
ECI-42.20-PE040	mm	172	187	202
ECI-42.40-PE040	mm	192	207	222
ECI-63.XX-PE040	mm	on request	on request	on request

Subject to alterations

# ECI motor.

## ECI-63.XX-K1



- Highly dynamic 3-phase internal rotor motor with EC technology
- Low cogging torque
- Robust, noise-optimized ball bearing system for a long service life
- High efficiency and high power density realized in a compact design
- Basic motor with electronic module K1 for operation with external control electronics
- Mechanical design and interfaces designed for modular flexibility
- Protection class IP 40 / IP 54 and connection by connector system

Nominal data							
Type		ECI-63.20-K1 -B00	ECI-63.20-K1 -D00	ECI-63.40-K1 -B00	ECI-63.40-K1 -D00	ECI-63.60-K1 -B00	ECI-63.60-K1 -D00
Nominal voltage ( $U_N$ )	V DC	24	48	24	48	24	48
Nominal speed ( $n_N$ )**	rpm	4 000					
Nominal torque ( $M_N$ )**	mNm	360	360	670	670	800	880
Nominal current ( $I_N$ )**	A	8.50	4.50	14.0	6.50	17.6	8.50
Nominal output power ( $P_N$ )**	W	150	150	280	280	335	370
Starting torque ( $M_{max}$ )	mNm	1 800	1 800	3 300	3 300	5 300	4 400
Permissible peak current ( $I_{max}$ )***	A	55	30	95	45	150	57
Speed at no-load operation ( $n_0$ )	rpm	5 800	6 800	5 900	5 900	6 100	6 000
No-load current ( $I_0$ )	A	0.50	0.30	0.70	0.32	1.30	0.45
Recommended speed control range	rpm	0 ... 5 000					
Rotor moment of inertia ( $J_R$ )	kgm <sup>2</sup> x10 <sup>-6</sup>	19	19	38	38	57	57
Motor constant ( $K_E$ )	mVs/rad	41.4	73.3	40.4	83.8	40.4	83.8
Connection resistance ( $R_c$ )	Ω	0.14	0.42	0.08	0.24	0.04	0.15
Connection inductance ( $L_c$ )	mH	0.26	0.88	0.14	0.57	0.09	0.33
Overload protection		To be implemented via the control electronics					
Permissible ambient temperature range ( $T_U$ )	°C	0 ... +40					
Weight	kg	0.90	0.90	1.20	1.20	1.50	1.50
Order no. (wire interface)*	IP 40	932 6320 103	932 6320 105	932 6340 103	932 6340 105	932 6360 106	932 6360 108
Order No. (connector interface)*	IP 54	932 6320 100	932 6320 102	932 6340 100	932 6340 102		932 6360 102
Subject to alterations		* Classification of protection class refers to installed state with sealing on the flange side The wave geometry for the IP54 version differs from the illustrated drawing					
Preferred type: ready to ship in 48 hours		** At $T_U$ max. 40°C *** Permissible time for peak current: max. 1 sec. – to be repeated only after complete cool down					

Additional information regarding the attachment components can be found in the main catalog or on the IDT website (idt.ebmpapst.com)

## Characteristic curve

ECI-63.20-K1, 24 V (at 25°C)

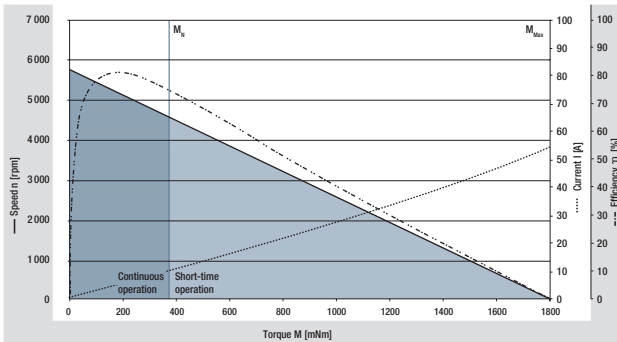

<sup>1)</sup> Nominal data, see table

Characteristic curve 48 V on request

ECI-63.40-K1, 24 V (at 25°C)

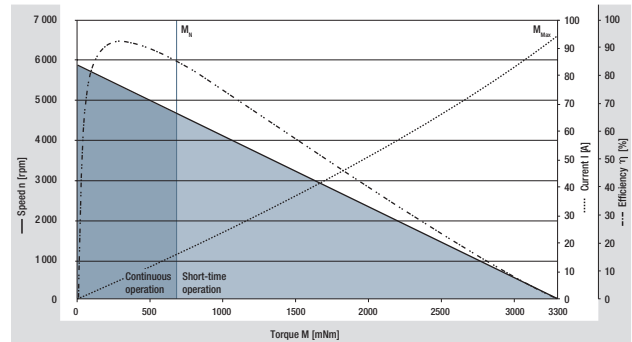

<sup>1)</sup> Nominal data, see table

Characteristic curve 48 V on request

ECI-63.60-K1, 24 V (at 25°C)

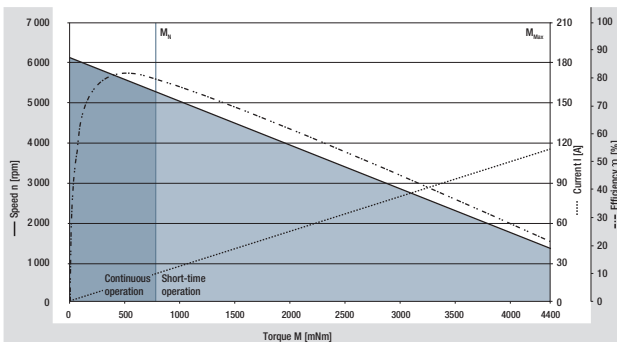

<sup>1)</sup> Nominal data, see table

Characteristic curve 48 V on request

## Modular construction kit

### Brake system

Spring-applied brake  
BFK 457-03

### Encoder system

Optical incremental encoder  
HEDS 5500

### Recommended external control electronics

VTD-XX.XX-K4S	Speed
VTD-60.13-K5SB	Position
VTD-60.35-K5SB	Position

### Basic motor

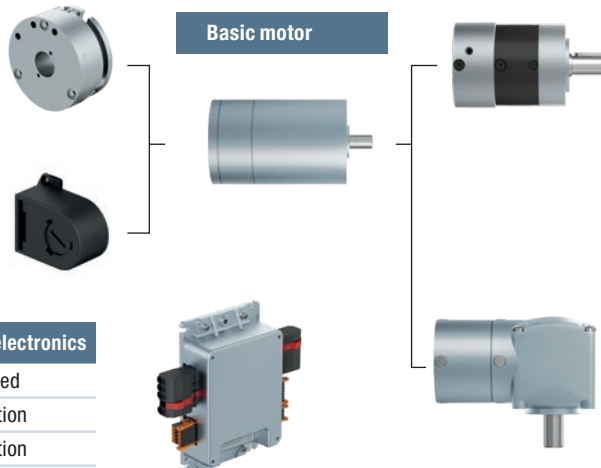

### Planetary gearheads

PE060 (page 14)  
PE040 (page 10)  
NoiselessPlus 63  
Performax® 63  
Performax®Plus 63  
Optimax 63

### Crown gearheads

EtaCrown® 75  
EtaCrown®Plus 63

# Planetary gearheads.

PE060

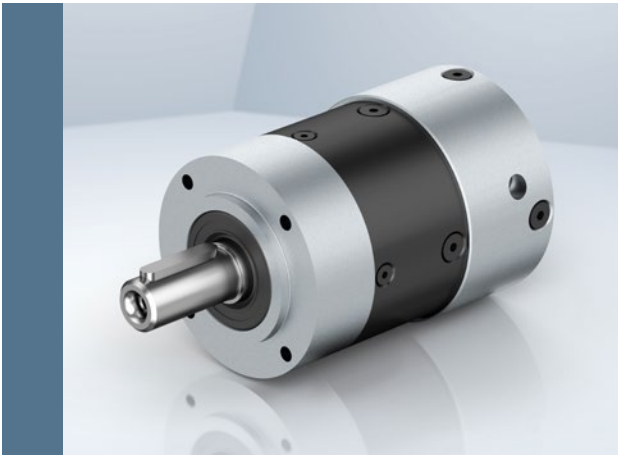
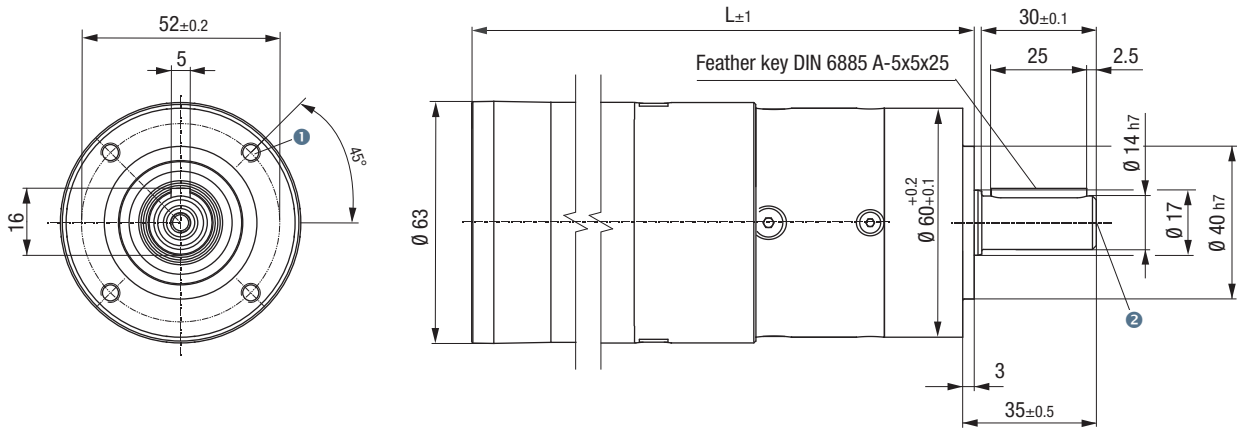

Image of 1-stage gearhead

- Case-hardened and ground ring gears
- Case hardened and ground planetary and sun gears ensure increased transmission quality and a long service life
- Low torsional play
- Easiest adaptation of motor and planetary gear through exchangeable flange modular system
- High level of flexibility through proven hollow shaft drive concept
- Integrated axial longitudinal compensation for compensation of the thermally-induced longitudinal expansion of the PTO shaft
- High efficiency and low-noise operation due to high tooth flank quality, needle-mounted planetary gears and high quality lubricant
- High torsional stiffness and high emergency stop torque due to robust gear design and optimized gear geometry

Nominal data					
Gearheads		PE040.1		PE040.2	
Reduction ratio*		5	8	25	40
No. of stages		1		2	
Efficiency		0.96		0.94	
Max. input speed (n <sub>i</sub> )	rpm	6 500		6 500	
Rated output torque (M <sub>ab</sub> )	Nm	40	20	46	46
Max. acceleration torque (M <sub>max</sub> )**	Nm	64	32	73.6	73.6
Emergency stop torque (M <sub>Not</sub> )***	Nm	80	40	92	92
Gear play	arcmin	≤9		≤11	
Permissible operating temperature (T <sub>v</sub> )	°C	-25 ... +90		-20 ... +80	
Operating mode		S1		S1	
Protection class	IP	64		64	
Weight	kg	1.0		1.2	
Shaft load radial	N	350		350	
Shaft load axial	N	450		450	
Service life	h	30 000		30 000	
Lubrication		Maintenance-free grease lubrication for life			
Installation position		any			
Subject to alterations		* Additional reductions and 3-stage designs on request ** Permitted for 30 000 loading cycles *** 1 000 times during the entire service life			



- ❶ 4 x M5 / 8 deep
- ❷ 1 x M5 / DIN 332

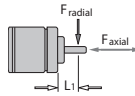

$F_{axial}$	165 N
$F_{radial}$	165 N
L1	17.5 mm

Permissible shaft load at nominal speed and life expectancy  $L_{10}$  (nominal operation) and operating factor  $C_b = 1$  (see page 22) of 30 000 h (at  $T_u$  40°C).

Length of the possible motor / gearhead combinations

Motor / gearhead		L - 1-stage	L - 2-stage	L - 3-stage
ECI-63.20-PE060	mm	192.1	207.1	222.1
ECI-63.40-PE060	mm	212.1	227.1	242.1
ECI-63.60-PE060	mm	232.1	247.1	262.1

Subject to alterations

# ECI motor.

## ECI-80.XX-K1



- Highly dynamic 3-phase internal rotor motor with EC technology
- Low cogging torque
- Robust, noise-optimized ball bearing system for a long service life
- High efficiency and high power density realized in a compact design
- Protection class IP 40/IP 54 and connection by connector system
- Basic motor with electronic module K1 for operation with external control electronics
- Mechanical design and interfaces designed for modular flexibility

Nominal data						
Type		ECI-80.20-K1 -B00	ECI-80.20-K1 -D00	ECI-80.40-K1 -B00	ECI-80.40-K1 -D00	ECI-80.60-K1 -D00
Nominal voltage ( $U_N$ )	V DC	24	48	24	48	48
Nominal speed ( $n_N$ )*	rpm	4 000				
Nominal torque ( $M_N$ )*	mNm	700	700	1 200	1 200	1 800
Nominal current ( $I_N$ )*	A	13.5	7.50	25.0	12.0	18.0
Nominal output power ( $P_N$ )*	W	293	293	503	503	754
Starting torque ( $M_{ms}$ )	mNm	2 400	2 500	3 900	5 000	5 600
Permissible peak current ( $I_{ms}$ )**	A	100	60	100	100	100
Permanent stall torque ( $M_{ns}$ )	mNm	700	700	1 200	1 200	1 800
Speed at no-load operation ( $n_0$ )	rpm	4 800	4 800	4 700	4 850	6 100
Speed at no-load operation ( $n_0$ )	rpm	1.00	0.70	1.50	0.90	1.00
No-load current ( $I_0$ )	A	0 ... 4 000				
Rotor moment of inertia ( $J_R$ )	kgm <sup>2</sup> x10 <sup>-6</sup>	54	54	104	104	155
Motor constant ( $K_E$ )	mVs/rad	47.2	94.1	48.2	96.0	72.2
Connection resistance ( $R_c$ )	Ω	0.07	0.30	0.03	0.10	0.04
Connection inductance ( $L_c$ )	mH	0.30	1.30	0.20	0.60	0.20
Overload protection		integrated				
Permissible ambient temperature range ( $T_U$ )	°C	-30 ... +40				
Weight	kg	1.40	1.40	2.10	2.10	2.70
Order no. (wire interface)**	IP 40	932 8020 103	932 8020 105	932 8040 103	932 8040 105	932 8060 105
Order no. (cable routing)**	IP 54	on request				
Subject to alterations		* At $T_U$ max. 40°C ** Permissible time for peak current: max. 5 sec. – to be repeated only after complete cool down *** Classification of protection class refers to installed state with sealing on the flange side				



## Characteristic curve

ECI-80.20-K1, 24 V (at 25°C)

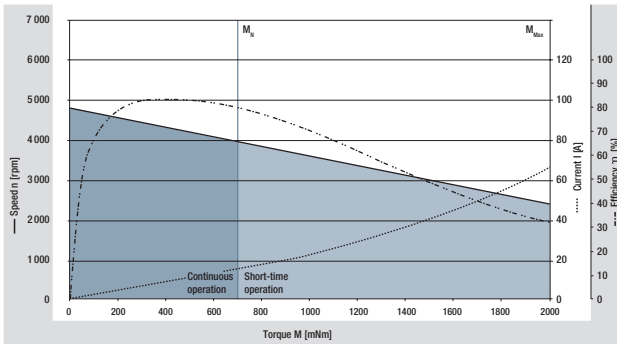

<sup>1)</sup> Nominal data, see table

Characteristic curve 48 V on request

ECI-80.40-K1, 24 V (at 25°C)

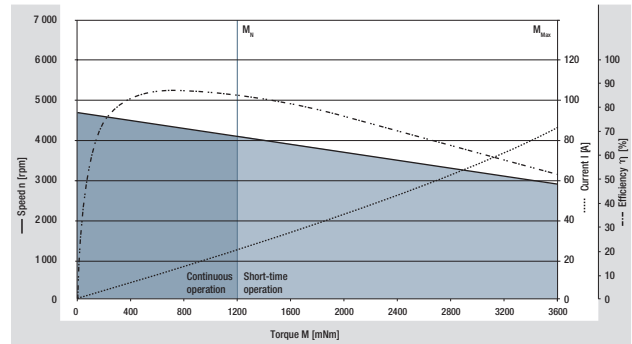

<sup>1)</sup> Nominal data, see table

Characteristic curve 48 V on request

ECI-80.60-K1, 48 V (at 25°C)

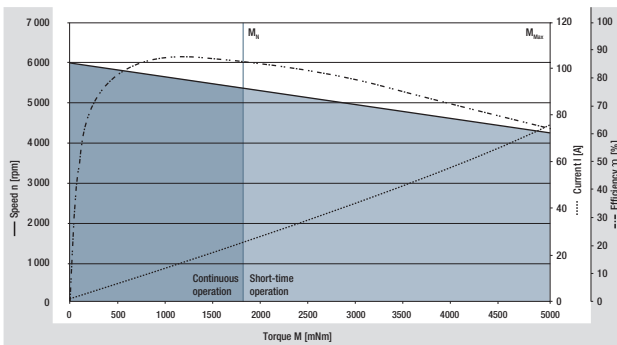

<sup>1)</sup> Nominal data, see table

## Modular construction kit

### Brake system

on request



### Basic motor



### Planetary gearhead

PE080 (page 18)

Performax®Plus 63

Optimax 63

### Encoder system

on request



### Recommended external control electronics

VTD-XX.XX-K4S Speed

VTD-60.35-K5SB Position



# Planetary gearheads.

PE080

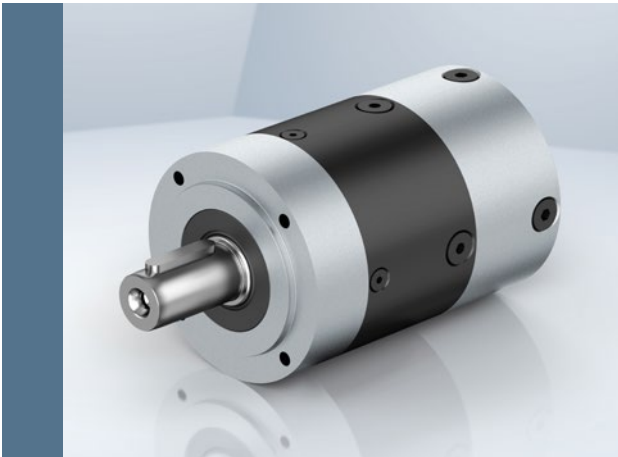
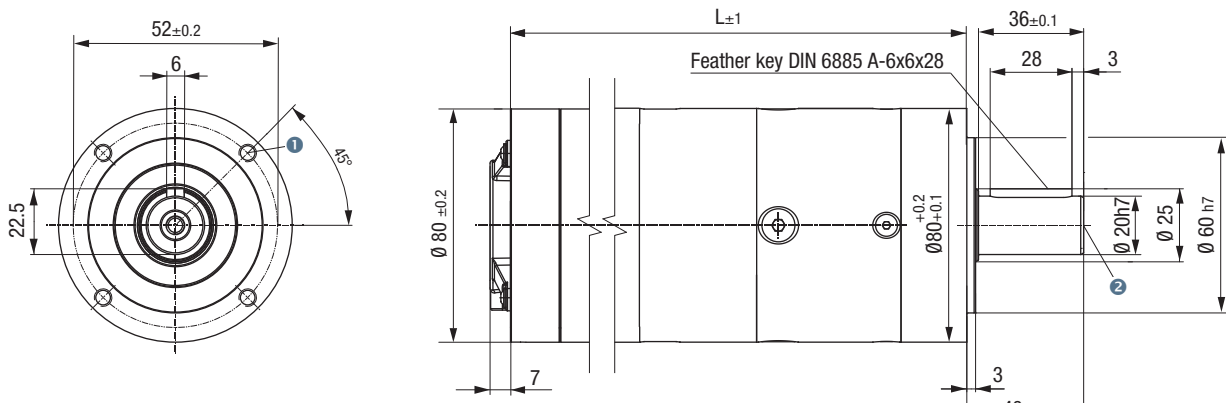

Image of 1-stage gearhead

- Case-hardened and ground ring gears
- Case hardened and ground planetary and sun gears ensure increased transmission quality and a long service life
- Low torsional play
- Easiest adaptation of motor and planetary gear through exchangeable flange modular system
- High level of flexibility through proven hollow shaft drive concept
- Integrated axial longitudinal compensation for compensation of the thermally-induced longitudinal expansion of the PTO shaft
- High efficiency and low-noise operation due to high tooth flank quality, needle-mounted planetary gears and high quality lubricant
- High torsional stiffness and high emergency stop torque due to robust gear design and optimized gear geometry

Neendaten					
Getriebe		PE080.1		PE080.2	
Reduction ratio*		5	8	25	40
No. of stages		1		2	
Efficiency		0.96		0.94	
Max. input speed (n <sub>i</sub> )	rpm	6 500		6 500	
Rated output torque (M <sub>ab</sub> )	Nm	115	55	125	125
Max. acceleration torque (M <sub>max</sub> )**	Nm	184	88	200	200
Emergency stop torque (M <sub>Not</sub> )***	Nm	230	110	250	250
Gear play	arcmin	≤7		≤9	
Permissible operating temperature (T <sub>v</sub> )	°C	-25 ... +90		-20 ... +80	
Operating mode		S1		S1	
Protection class	IP	64		64	
Weight	kg	2.3		2.8	
Shaft load radial	N	750		750	
Shaft load axial	N	900		900	
Service life	h	30 000		30 000	
Lubrication		Maintenance-free grease lubrication for life			
Installation position		any			
Subject to alterations		* Additional reductions and 3-stage designs on request ** Permitted for 30 000 loading cycles *** 1 000 times during the entire service life			



- ❶ 4 x M6 / 10 deep
- ❷ 1 x M6 / DIN 332

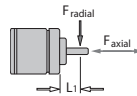

$F_{axial}$  350 N  
 $F_{radial}$  see table  
 $L1$  12.5 mm

Permissible shaft load at nominal speed and life expectancy  $L_{10}$  (nominal operation) and operating factor  $C_b = 1$  (see page 22) of 30 000 h (at  $T_U$  40°C).

**Length of the possible motor / gearhead combinations**

Motor / gearhead		L - 1-stage	L - 2-stage	L - 3-stage
ECI-80.20-PE080	mm	208	222.5	237
ECI-80.40-PE080	mm	228	242.5	257
ECI-80.60-PE080	mm	248	262.5	277

Subject to alterations

# Standards and guidelines.

## Basic information on standards and guidelines for electrical small-power motors and drive systems operated with a DC voltage of max. 75 V DC (nominal voltage):

The ECI series described in this catalog are direct current motors in an electronically commutated design, which are designed and specified for a nominal voltage of max. 75 V DC. Thus the supply voltage of these drives is within the range of safety extra-low voltage (SELV). On this basis, ebm-papst would like to provide some information intended to help you understand the classification of the motors from the relevant EC Directives and the resulting consequences.

### The CE label

In order to ensure a uniform safety level in the European internal market, the European commission has implemented a new approach for technical harmonization. This has been welcomed by all relevant parties and is visible in many products as a CE label giving proof of agreement with the harmonized provisions.



What does CE actually mean? Why don't all products bear the CE label?

CE is the abbreviation for "Communauté Européenne". The harmonized statutory provisions are a framework directive and belong to the so-called New Approach. This framework directive defines the basic requirements, putting in circulation and operation as well as the applicable conformity assessment process. The manufacturer of a product must now decide which framework directive applies to which product. For electrical small-powered motors the following framework directive can be applied:

- 1) Machinery Directive 2006/42/EC
- 2) Low Voltage Directive 2014/35/EU
- 3) EMC Directive 2014/30/EU

Based on these directives, ebm-papst St. Georgen GmbH & Co. KG does not mark the electric motors and drive systems described with the "CE" mark and does not issue an EC Declaration of Conformity. The reason for this is consideration of the relevant EC Directives and the definitions of the terms used, "Electric motor" and "Drive system", by ebm-papst St. Georgen GmbH & Co. KG.

### Definition of the electric motor

An electric motor is a motor without electronics or a motor with integrated electronics of low complexity, such as commutation sensors, simple commutation electronics or commutation electronics with simple speed control with a voltage range of <75 V DC (nominal voltage) for use by customers who incorporate them into end devices.

According to this definition, electric motors include, for example, the ECI-XX.XX-K1 series.

### Definition of drive systems

Drive systems are motors with built-in electronic control systems that have a certain degree of complexity. These include electronic control systems which, in addition to a speed control, offer other functions such as current control or position control. This also includes electronic control systems which, for example, have a CANopen interface or that can be operated via programmable sequential controls. For these drive systems, the voltage range of <75 V DC (nominal voltage) and the intended use by customers who will use the systems in end devices also apply. Drive systems include the ECI-XX.XX-K3, ECI-XX.XX-K4 and ECI-XX.XX-K5 series, for example.

### Reasons according to the Machinery Directive 2006/42/EC

Electric motors are expressly exempt in Art. 1, Par. (2), lit. k) and thus are NOT given the CE mark.

According to the definition of the term in Art. 2, lit. g), a drive system is an "incomplete machine" and thus does not receive a CE mark, but falls under the process for incomplete machines according to Art. 13. Installation instructions to Annex IV and a Declaration of Incorporation to Annex II, Part 1, Section B are available for each drive system. The specific technical documents to Art. 13, Par. (1), lit. a) have been created in-house and are archived for the government agencies of the individual countries.

Based on this directive, the machine manufacturer is responsible for verifying and ensuring compliance with the basic requirements of the Machinery Directive.

### Reasons according to the Low Voltage Directive 2014/35/EU

Due to the voltage ranges (nominal voltage), the specified electric motors and drive systems do not fall under the application area of the low voltage directive according to Art. 1.

### **Reasons according to the EMC Directive 2014/30/EU**

Because they are sold exclusively to customers who incorporate them into end devices and not to the end user, the specified electric motors and drive systems do not fall under the application area of the EMC directive according to the definition of the term in Art. 3, Par. (2), 1: As the small motors are supplied to companies who incorporate them into end devices and not to the end user, ebm-papst has no control over further use of the pre-fabricated components in devices, machines or installations. Therefore, ebm-papst provides express notice that the system manufacturer must provide a suitable EMC circuit when selecting the power supply and must provide for EMC-compliant installation and use in the devices. For more information about EMC-compliant installation and EMC safety measures, refer to resources such as the IEC 61000-5-x series (Installation and Mitigation Guidelines).

### **Proper use**

All drives in this catalog are determined for installation in permanently connected, stationary end devices and machines in the industrial area and must be operated on electricity only when in installed condition! Operation is prohibited until it has been ascertained that this product, along with the machine into which this product is to be installed, complies with the protective requirements of the Machinery Directive. If, when using our drives, market or application-specific product standards apply, compliance with these must be verified and ensured by the device manufacturer. This product is not intended for the end consumer.

## **RoHS** **European Directive EC No. 2011/65/EU (RoHS)** **Legally regulated substances**

As an innovative company and trendsetter in the world of air technology and drive engineering, ebm-papst feels a special obligation towards the environment. Accordingly, under the GreenTech logo, we have implemented a comprehensive concept that extends from the origin to the use of our products. This includes, of course, protecting our environment and using natural resources in a way that conserves them. This applies equally to our manufacturing processes and to our products.

When developing our products, we already take into consideration any possible negative consequences they may have for the environment.

Our goal is to prevent such environmental impact-even beyond the extent mandated by law-or to reduce it to a minimum, and thus to ensure sustainable development of our products. Thus we ensure that our products are free of materials and substances that are prohibited by law.

Of course, all current products have been designed for conformity with European Directive 2011/65/EU (RoHS). All older products that do not yet conform to these directives or parts thereof will be consistently redesigned. Our suppliers are required to provide us only with goods that conform to the directives. Thus we can confirm that basically, all of our products listed in this catalog conform to the above-mentioned directive. We are also available to help with any other questions you may have on both these topics.

### **REACH Directive (EC No. 1907/2006)**

The EU legal regulation for Registration, Evaluation, Authorization and Restriction of Chemical substances (REACH) entered into force on 1 June 2007. This is a chemicals law intended to provide maximum protection to health and the environment. As defined by the REACH directive, ebm-papst is a downstream user. The units you purchase from us are products as defined by REACH and thus do not require registration. However, in our own interest and to ensure a high degree of product safety, we track the implementation of REACH and the resulting requirements as part of our duty to provide information. To comply with the requirements of REACH, we are in contact with all suppliers from whom we obtain chemicals (substances), preparations and components that we use as part of our production process. Within this framework, ebm-papst fulfills the obligations set forth in the REACH regulation. If you have any other questions about the implementation of the REACH directive in our company, please do not hesitate to contact us.

# Operating factor, lifetime, efficiency.

## Operating factor $c_b$

To achieve a uniform lifetime for the gearheads and motors, the necessary torques  $M$  must be increased by the respective operating factor  $c_b$  under the various operating loads so as not to exceed the maximum permissible gearhead torque  $M_{2,max}$  (see table below).

Operating modes									
	Load			Operating period in h/days					
	even	gradual	sudden	3 h	8 h	24 h	3 h	8 h	24 h
				up to 10 switching ops./h			over 10 switching ops./h		
One rotation direction	•			1.00	1.00	1.20	1.00	1.20	1.52
Rotation direction change	•			1.00	1.30	1.59	1.20	1.59	1.92
One rotation direction		•		1.11	1.30	1.59	1.30	1.52	1.82
Rotation direction change		•		1.41	1.72	2.00	1.59	1.89	2.33
One rotation direction			•	1.20	1.52	1.82	1.52	1.82	2.22
Rotation direction change			•	1.59	2.00	2.33	2.00	2.33	2.86

## Operating mode

It is necessary to define the operating mode under which a gear motor can be operated with certain nominal values in order to avoid overloading the motor and/or the gearhead. The values stated in this catalog refer to S1 operation (continuous operation). This means that the gear motor can be constantly operated with the stated values, but can also have a higher load placed on it for a short time. Please contact us if you require more information about this.

## Lifetime

Lifetime is limited by the various components in the drive. If frequently overloaded, the gearhead components are subjected to more wear than under nominal load. Extreme ambient and operating conditions cause a reduction in the lifetime guaranteed for operation under operating ratio  $c_b = 1$ .

## Efficiency $\eta$ (eta)

The efficiency per gear stage is at least 90%. Depending on the tooth configuration and on the manufacturing quality, far better levels of efficiency can also be achieved. The following overall efficiencies were obtained for multi-stage gearheads:

Overall efficiency	
for 1-stage gearhead	$\eta = 0.9$
for 2-stage gearhead	$\eta = 0.9^2 = 0.81$
for 3-stage gearhead	$\eta = 0.9^3 = 0.73$
for 4-stage gearhead	$\eta = 0.9^4 = 0.66$
for 5-stage gearhead	$\eta = 0.9^5 = 0.59$

# ebm-papst around the world.

## ebm-papst St. Georgen GmbH & Co. KG

### Hauptverwaltung

Hermann-Papst-Straße 1  
78112 St. Georgen  
GERMANY  
Phone +49 7724 81-0  
Fax +49 7724 81-1309  
info2@de.ebmpapst.com

## ebm-papst St. Georgen GmbH & Co. KG

### Werk 7 Lauf

Industriestraße 9  
91207 Lauf a. d. Pegnitz  
GERMANY  
Phone +49 9123 945-0  
Fax +49 9123 945-145  
info4@de.ebmpapst.com

## Germany

### Motor specialist

#### Northern region

**Norderstedt**  
Breuell & Hilgenfeldt GmbH  
Udo Wildenblanck  
Regional Sales Manager – Drive Technology  
Oststraße 96  
22844 Norderstedt  
Phone +49 9123 945-291  
Fax +49 9123 945-5291  
Udo.Wildenblanck@de.ebmpapst.com

### Motor representative

#### Central / eastern region

**Southern / eastern region 1**  
Dipl. oec. (VWA) Henry Sämisch  
Waldweg 3  
15926 Luckau  
Phone +49 9123 945-292  
Fax +49 9123 945-5292  
Henry.Saemisch@de.ebmpapst.com

### Motor specialist

**Central / western region**  
Markus Psik  
Am Dreispitz 16  
69502 Hemsbach  
Phone +49 9123 945-293  
Fax +49 9123 945-5293  
Markus.Psik@de.ebmpapst.com

### Motor representative

**Southern / western region**  
**Meißenheim**  
Michael Weber  
Karlstraße 17  
77974 Meißenheim  
Phone +49 9123 945-294  
Fax +49 9123 945-5294  
Michael.Weber@de.ebmpapst.com

### Motor specialist

**Southern / eastern region 2**  
**Munich**  
Dipl. Eng. (Univ.) Patrick Christleven  
Faustnerweg 10  
81479 Munich  
Phone +49 9123 945-295  
Fax +49 9123 945-5295  
Patrick.Christleven@de.ebmpapst.com

## Europe

### Motor representative

**France**  
ebm-papst sarl  
Parc d'Activités Nord  
1 rue Mohler – BP 62  
67212 Obermai Cedex  
Phone +33 3 88 66 88 03  
info@ebmpapst.fr  
www.ebmpapst.fr

### Motor representative

**Great Britain**  
ebm-papst Automotive & Drives (UK) Ltd.  
The Smithy  
Fidlers Lane  
East Ilsley, Berkshire RG20 7LG  
Phone +44 1635 2811-11  
Fax +44 1635 2811-61  
adsales@uk.ebmpapst.com  
www.ebmpapst-ad.com

### Motor representative

**Italy**  
ebm-papst Srl  
Via Cornaggia 108  
22076 Mozzate (Co)  
Phone +39 0331 8362013  
Fax +39 0331 821510  
info@it.ebmpapst.com  
www.ebmpapst.it

### Motor representative

**Benelux**  
ebm-papst Benelux B.V.  
Polbeemd 7 – 5741 TP Beek en Donk  
P.O. Box 140 – 5740 AC Beek en Donk  
Phone +31 492 502-900  
Fax +31 492 502-950  
verkoop@nl.ebmpapst.com  
www.ebmpapst.nl

### Motor representative

**Austria**  
ebm-papst Motoren & Ventilatoren GmbH  
Straubingstraße 17  
4030 Linz  
Phone +43 732 321150-0  
Fax +43 732 321150-20  
info@at.ebmpapst.com  
www.ebmpapst.at

### Motor representative

**Russia**  
ebm-papst Rus GmbH  
Olimpiyskiy prospect 29A, office 418  
141006 Mytistschi, Oblast Moscow  
Phone +7 495 9807524  
Fax +7 795 5140924  
info@ebmpapst.ru  
www.ebmpapst.ru

### Motor representative

**Sweden**  
ebm-papst AB  
Äggelundavägen 2  
17562 Järfälla  
Phone +46 10 4544400  
Fax +46 8 362306  
info@ebmpapst.se  
www.ebmpapst.se

### Motor representative

**Switzerland**  
ebm-papst AG  
Rütisbergstraße 1t  
8156 Oberhasli  
Phone +47 44 73220-70  
Fax +41 44 73220-77  
verkauf@ebmpapst.ch  
www.ebmpapst.ch

## America

### Motor representative

**USA**  
ebm-papst Automotive & Drives Inc.  
3200 Greenfield, Suite 130  
Dearborn, MI 48120  
Phone +1 313 406-8080  
Fax +1 313 406-8081  
automotive@us.ebmpapst.com  
www.ebmpapst-automotive.us

## Asia

### Motor representative

**China**  
ebm-papst Ventilator (Shanghai) Co., Ltd  
No. 418, Huajing Road  
WaiGaoQiao Free Trade Zone  
200131 Shanghai  
Phone +86 21 5046-0183  
Fax +86 21 5046-1119  
sales@cn.ebmpapst.com  
www.ebmpapst.com.cn

### Motor representative

**India**  
ebm-papst India Pvt. Ltd.  
26/3, G.N.T. Road Erukkencherry  
600 118 Chennai  
Phone +91 44 26720103  
Fax +91 44 25371149  
sales@in.ebmpapst.com  
www.ebmpapst.in

**ebm-papst St. Georgen  
GmbH & Co. KG  
Hauptverwaltung**

Hermann-Papst-Straße 1  
78112 St. Georgen  
GERMANY  
Phone +49 7724 81-0  
Fax +49 7724 81-1309  
info2@de.ebmpapst.com

**ebm-papst St. Georgen  
GmbH & Co. KG  
Werk 7 Lauf**

Industriestraße 9  
91207 Lauf a. d. Pegnitz  
GERMANY  
Phone +49 9123 945-0  
Fax +49 9123 945-145  
info4@de.ebmpapst.com

**ebmpapst**

The engineer's choice